



## Multiposition Microelectric Valve Actuators

Models EMH and EMT

### Quick Start Guide

The microelectric multiposition actuator consists of a control module, a stepper motor/gearbox assembly, a manual controller (use is optional), a universal AC input (100-240 VAC, 50-60 Hz) to 24 VDC power supply, and the interconnecting cables.

### Cable and Connector Functions

**Figure 1** on the next page shows the functions of the cables supplied with the microelectric actuator. There are four connectors on the control module, keyed and sized to prevent incorrect connection.

Input power (20 – 30 VDC, with 24 – 28 VDC preferred) is supplied through a miniature power connector: the inner pin is + voltage and the outer is ground. Average DC current requirement is 2.5 amps. Standby current is less than 100 milliamps. The actuator should not share a power supply with other noise-sensitive electronics, as the high current draw can cause problems.

Motor driver output is through the 10 pin connector. The 26-pin connector is for the manual controller and remote digital input/output signals; the actuator can be controlled by *either or both*. The manual controller has a pass-through port, so an additional cable can provide simultaneous control by an external system. The three-pin connector is for RS-232 interface. The serial and digital functions are fully described in Technical Note 415, available from Valco or from the support section of our website at [www.vici.com](http://www.vici.com).

### Mounting

The actuator should be oriented so that any potential leakage of liquid from the valve or fittings flows away from rather than into the actuator, as indicated below.

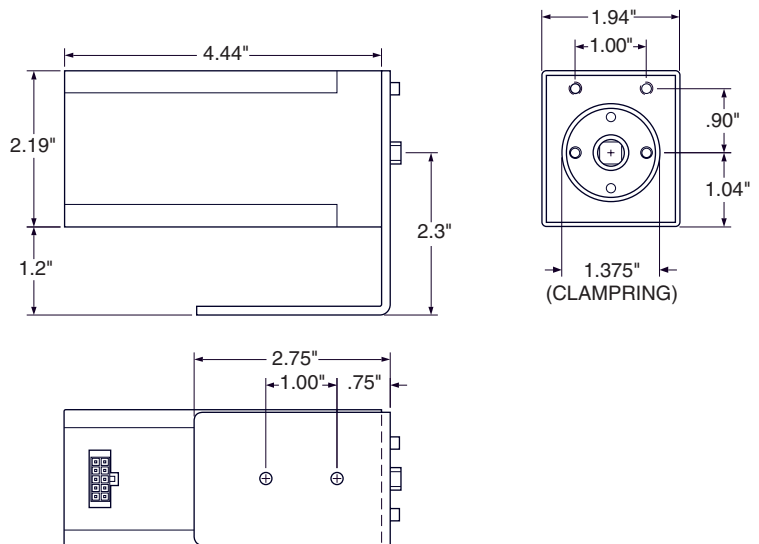
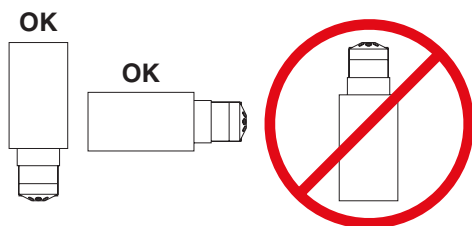

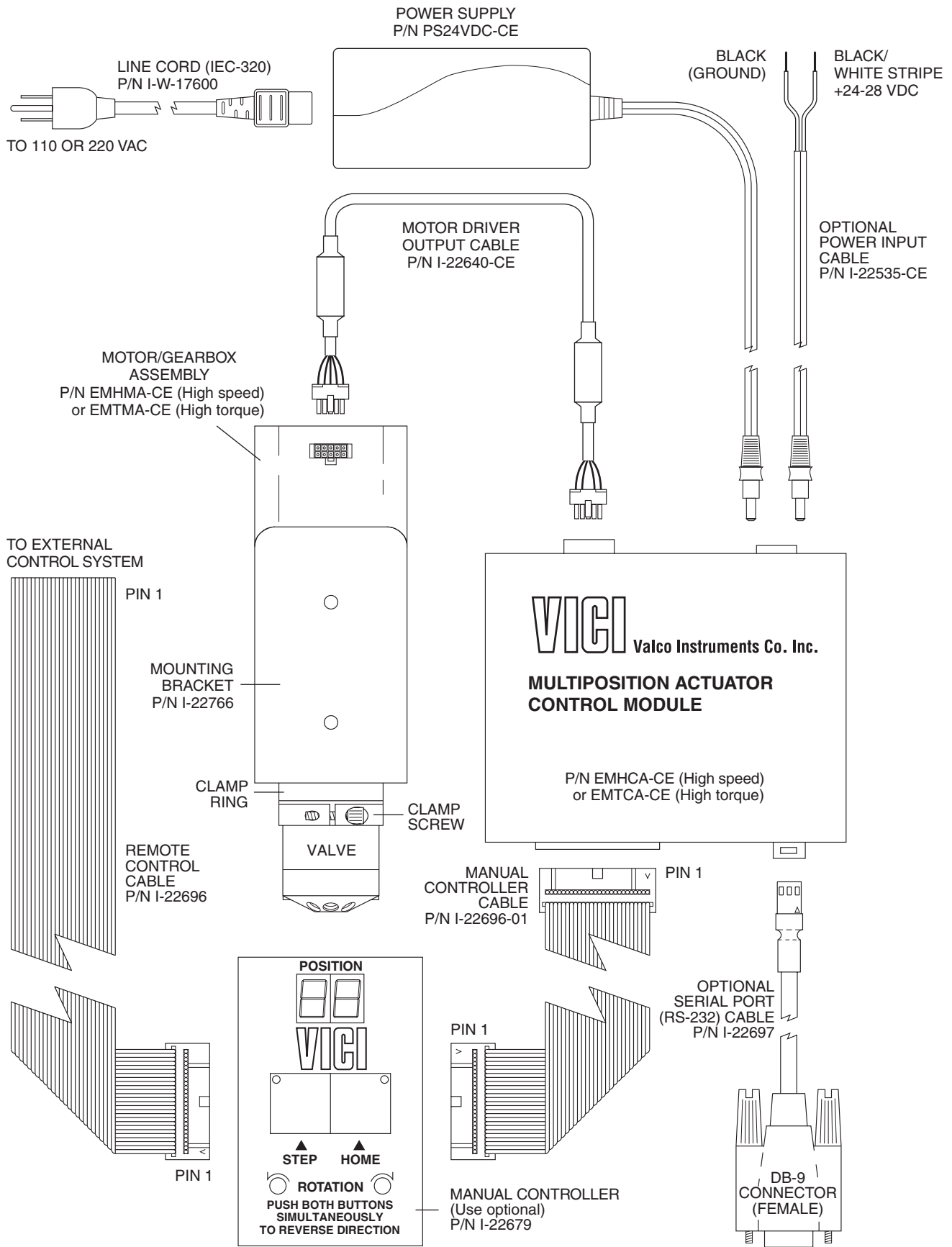

**Figure 1: Actuator and controller connections**

Pin	Color	Signal	Direction	Pin	Color	Signal	Direction
1	brown	Home	Input	14	yellow	4 BCD	Output
2	red	Motor run	Output	15	green	20 BCD	Output
3	orange	Step	Input	16	blue	2 BCD	Output
4	yellow	Error	Output	17	violet	10 BCD	Output
5	green	Manual Dir.	Input	18	gray	1 BCD	Output
6	blue	Direction	Output	19	white	80 BCD	Input
7	violet	Auto Dir.	Input	20	black	8 BCD	Input
8	gray	Data latch	Input	21	brown	40 BCD	Input
9	white	+5 VDC 100 ma	Output	22	red	4 BCD	Input
10	black	Ground	Output	23	orange	20 BCD	Input
11	brown	80 BCD	Output	24	yellow	2 BCD	Input
12	red	8 BCD	Output	25	green	10 BCD	Input
13	orange	40 BCD	Output	26	blue	1 BCD	Input

**Pin signal definitions for the Digital Input/Output cable**

## Manual Controller

The manual controller allows the user to select the rotation direction, set the total number of positions, and control the STEP and HOME functions. The controller is connected to the actuator control module with the 26 pin ribbon cable. The manual controller has two functional modes – the operating mode and the setup mode. The display indicates the current position in the operating mode, the total number of positions in the setup mode, and an “EP” when there is a positioning error.

### Operating Mode

This is the default mode; that is, the controller will be in this mode when it is initially powered. In this mode the STEP and HOME functions are clearly labelled as the primary functions of the left and right switches, respectively. To change the direction of rotation, momentarily depress the STEP and HOME switches simultaneously. The DIRECTION LEDs will change, indicating that the direction has reversed.

### Setup Mode

To shift into the setup mode, depress the STEP and HOME switches and hold them down for 8 seconds. The position display LEDs will begin to flash, displaying the current setting for the total number of positions in a full rotation. Use the STEP switch to increase or the HOME switch to decrease this setting to the desired number of positions. To return to the operating mode, depress both switches until the LEDs stop blinking.

## Simultaneous Use of the Manual Controller and an External Control System

The manual controller has two identical connectors for input and/or output, permitting an external system to be used simultaneously with the manual STEP and HOME commands. However, *the following precaution should be observed:*

If the STEP and HOME functions are to be used by *both* systems, the external system control output cannot be in the form of TTL signals; instead, the output must be a momentary signal asserted by a contact closure or open collector driver. While TTL signals will cause no damage to either system, they will effectively override the manual controller.

### Connecting External Systems

An external control system can be connected to the actuator in several ways:

1. The Digital Input/Output connector is a 26 pin dual in-line connector which can mate to a mass terminatable flat cable connector available from a number of manufacturers. The flat cable can then be integrated into the control system.
2. The manual controller can be connected to the control module, and then a 26 pin dual in-line connector and flat cable assembly can be attached to the manual controller. This allows dual control as well as a visual indication of the actuator position.
3. A serial port can be connected from a host control system to the actuator, using the optional RS-232 cable (Product No. I-22697).

### Connections for Remote Control

The remote control cable (I-22696) can be connected to your TTL or contact closure relays to provide automated remote control of the actuator. Be sure to refer to your systems manual to make certain that the relays you plan to use are TTL (5 volts max.) or dry contact closure. Using a powered relay with >5 volts may result in damage to the controller.

For STEP control, connect Pin 10 (the black wire closest to Pin 1) to one relay terminal and Pin 3 (the orange wire closest to Pin 1) to the other terminal. (*Refer to **Figures 1 and 2** as required.*)

For HOME control, connect Pin 10 (the black wire closest to Pin 1) to one relay terminal and Pin 1 (the brown wire) to the other terminal.

A momentary closure (50 msec minimum) of the relay will STEP or HOME (Position 1) the actuator. The relay should be turned off with 5 seconds of being turned on to properly enable the manual override function of the manual controller.

### For More Information

For detailed information on digital control, serial control, switching times, and other optional features, refer to Technical Note 415 in the support section of [www.vici.com](http://www.vici.com), or request a copy by calling 713-688-9345 or (int) +41-41-925-6200.

North America, South America, and Australia/Oceania contact:

**VICI**® Valco Instruments Co. Inc.  
P.O. Box 55603  
Houston, TX 77255  
Sales: (800) 367-8424  
Tech: (713) 688-9345  
Fax: (713) 688-8106 [valco@vici.com](mailto:valco@vici.com)

Europe, Asia, and Africa contact:

**VICI**® VICI AG International  
Parkstrasse 2  
CH-6214 Schenkon  
Switzerland  
Phone: +41 41 925 6200  
Fax: +41 41 925 6201 [info@vici.ch](mailto:info@vici.ch)

Cheminert® and VICI® are registered trademarks of Valco Instruments Co. Inc. and VICI AG

TN-415QS 10/14