



**Valco Instruments Co. Inc.**

# **Dynacalibrator Model 345 Instruction Manual**

Manufactured by:

**Valco Instruments Co. Inc.**  
8300 Waterbury  
Houston, TX 77055

3/16

---

*North America, South America, and Australia/Oceania contact:*  
**VICI Valco Instruments Co. Inc.**  
800 · 367 · 8424 sales  
713 · 688 · 9345 tech  
713 · 688 · 8106 fax  
valco@vici.com

*Europe, Asia, and Africa contact:*  
**VICI VICI AG International**  
Schenkon, Switzerland  
Int + 41 · 41 · 925 · 6200 phone  
Int + 41 · 41 · 925 · 6201 fax  
info@vici.ch

## Symbols used in this document



Attention



Radiant heat warning



Entanglement warning



Electrical warning

# Table of Contents

---

Introduction	
General Description.....	1
Dynacal® Permeation Devices.....	1
How to Use This Manual.....	1
Basic Design .....	1
Specifications.....	3
Getting Started .....	4
Initial Receiving Inspection/Check.....	4
Unpacking the Dynacalibrator .....	4
Concealed Damage .....	5
Unit Location.....	6
Permeation Device Conditioning.....	6
Rear Panel Connections .....	7
Supply Inlet.....	7
Span Outlet.....	8
Overflow Vent .....	8
Front Panel Features.....	8
Initial Set-Up .....	10
Remote Control Connections.....	10
Connections .....	10
Chamber Temperature .....	10
Setting the Oven Temperature Limit.....	11
Installing the Permeation Device(s).....	12
Configuration.....	13
Setup Screen .....	13
Tubes Screen .....	14
Basic Operation.....	15
Manual Mode.....	15
Auto Mode.....	16
Quick Glance Status Bar .....	17
Historical Display Graph.....	18
Analyzer Calibration.....	20
Manual Mode.....	20
Auto Mode.....	20
Shutdown Procedure.....	21
Advanced Theory of Operation.....	22
Electrical Description.....	23
Maintenance .....	24
Instrument Inspection and Cleaning .....	24
Dilution Flowmeter Calibration.....	25
Chamber Temperature Calibration .....	25
Model Number Breakdown.....	26
Warranty .....	27



**If this equipment is used outside manufacturers' specification the protection provided by the equipment may be impaired.**

---

---

# Introduction

---

## General Description

VICI Metronics Dynacalibrators® use Dynacal® permeation devices to generate the precise gas concentrations necessary for calibrating air pollution analyzers, monitors, and other instruments that measure gas concentrations in the parts-per-million range and lower.

Dynacalibrators are available in three models, each with a large variety of optional features to fit a wide range of calibration requirements. All critical factors, such as permeation rates, gas flow rates, and permeation chamber temperatures are calibrated against standards traceable to the National Institute of Standards and Technologies.

Model 345 specifications are listed on page 3.

## Dynacal Permeation Devices

Metronics Dynacal permeation devices are the simplest and most reliable method for supplying a source of trace quantities of various gases. They can accommodate virtually any requirement for generating low concentrations of gases. Permeation rates from thousands of ng/min down to fractional parts of a ng/min are possible. The devices can be supplied filled with any one of hundreds of different compounds, both organic and inorganic.

## How to Use This Manual

This manual provides installation, operation, and maintenance information for all configurations of the Model 345. The identification tag on the rear panel of every Dynacalibrator is stamped with the unit's complete model number, which reflects the exact unit configuration. A chart on the last page of the manual explains the model numbers.

## Basic Design

The Model 345 contains two mass flow controlled (MFC) systems – the carrier system and the dilution system. The carrier gas system is typically a fixed flow which passes through the permeation chamber containing the permeation device. The temperature of the chamber, which controls the permeation rate of the calibration gas from the permeation device, is tightly regulated to provide both accurate and precise results. The chamber temperature is adjusted from 30°C (or 2°C above ambient, whichever is higher) to 110°C. The carrier stream mixes with the calibration gas in the chamber and is then fed forward to the mixing tee.

In standard models (**Figure 1**) the dilution gas stream is controlled and measured by the diluent MFC, and feeds forward to the other side of the mixing tee. The mixture of the carrier and the diluents is then fed to the distribution tee, which allows the flow to move to the Span Out and the Overflow bulkhead connectors for distribution.

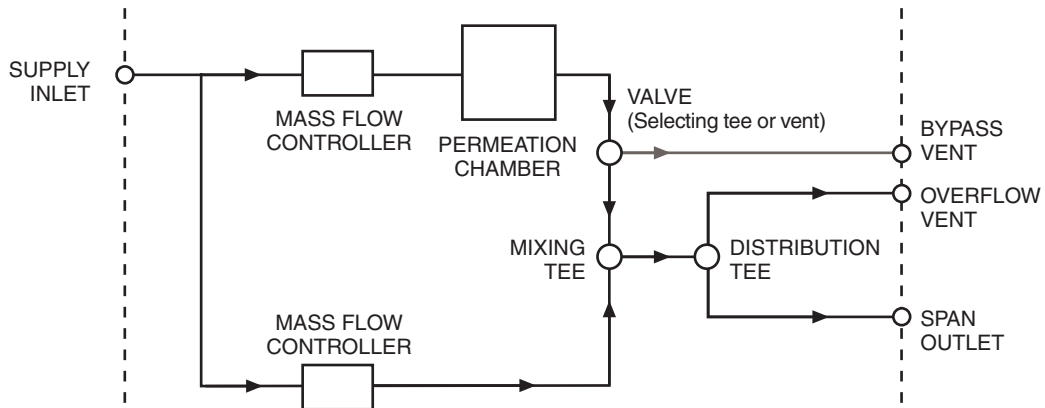

**Figure 1:** Model 345 plumbing schematic

The Model 345 has one valve to direct the carrier flow. In the Span position, the dilution stream and carrier streams pass through the mixing tee.

Opportunities for setting and monitoring the flows for the diluent and carrier MFC are provided in several screens on the touch panel controller. Instructions for setting and monitoring these controls are covered in the “Initial Set-Up” section of this manual, which begins on page 10.

**Note:** Excess span gas is wasted to the overflow vent to ensure that span gas is delivered at near atmospheric pressure, for those analyzers which are sensitive to sample feed pressure. The overflow vent is usually left open, but can be plumbed to an external exhaust port. Any exhaust plumbing must be sized so there is no increase in pressure into the analyzer under calibration.

**CAUTION:**

**If the span gas is composed of a compound that is toxic, hazardous, or in any other way a threat to life or safety at the concentrations being generated, the overflow port must be vented to an appropriate scrubber or abatement system selected for the specific gas.**



**However, this can present challenges to proper operation of this instrument; if the scrubber/abatement system is setup to run with inputs at negative pressure, there can be conditions in which sample can be “robbed” from the Span Out port.**

## Specifications

### Operational

#### Flow controls

Output concentration range	Fractional ppb to hundreds of ppm
Carrier flow rate (nominal)	100 – 400 sccm
Dilution flow rate range(nominal)*	1 -20 SLPM *(depending on model)
Dilution flow accuracy	+/- 1% of Setpoint from 20%-100% of full scale, +/- .2% of full scale between 2% - 20% of range
Operating temperature range	10° to 50°C (50° - 122°F)

#### Permeation Chamber

Temperature range*	30° - 110°C *(Must be at least 2°C above ambient)
Temperature setpoint accuracy	+/- 0.05°C (NIST-Traceable) from 30°C -110°C
Temperature setpoint repeatability	+/- 0.01°C at any fixed ambient temperature
Temperature equilibrium time	1.5 hours for highly dynamic changes
Chamber size	Accepts devices up to 23.5 cm X 1.6 cm diameter
Modes	(Auto or Manual) Span Out
Operating Duty Cycle	Continuous

### Environmental

Operating noise emission	45 to 50 dBA
Ambient operating temperature	20°C to 35°C
Operating humidity	0-95% relative humidity
Storage temperature	10° C to 40°C
Storage humidity	0 – 50% relative humidity

### Power requirements

Voltage, frequency, power	100-240 VAC, 50/60 Hz, 150 Watts maximum
---------------------------	--

## Getting Started

---

Every Dynacalibrator is completely calibrated, thoroughly tested and inspected, and carefully packed prior to shipment. The carrier has assumed responsibility for its safe delivery upon acceptance of the shipment.

### Initial Receiving Inspection/Check

On receipt of your unit, before signing the waybill and releasing the carrier's agent, inspect the shipment for the following:

1. The number of cartons received tallies with that on the waybill.
2. The weight of the shipment agrees with that on the waybill.
3. There is no visible evidence of damage to the shipment or its containers.

Any discrepancies to the above must be clearly described on the waybill and signed by the carrier's agent. Failure to adequately describe such external evidence of loss or damage may result in the carrier refusing to honor any subsequent claim.

### Unpacking the Dynacalibrator

After the initial receiving inspection and check, the Dynacalibrator may be unpacked. A carefully sized and mated pair of shipping cartons have been designed to ensure against any damage to the Dynacalibrator while it is in transit. Use the following procedures to remove the instrument from the packaging, referring to **Figure 2** as necessary.



**Save all the packing materials – both cartons, the eight corner blocks, and the two inner carton supports – for any future shipment of the Dynacalibrator.**

---

1. Neatly slit the shipping tape along the edges of the flaps on the top of the carton with a knife. Do not try to pull or tear the tape.
2. Open the outer carton and remove the four corner blocks on top of the inner carton.
3. Neatly slit the shipping tape along the edges of the flaps on the top of the inner carton with a knife. Take care to penetrate the tape with the knife only far enough to cut it. The Dynacalibrator is directly beneath the flaps.
4. Carefully lift the Dynacalibrator out of the inner carton.



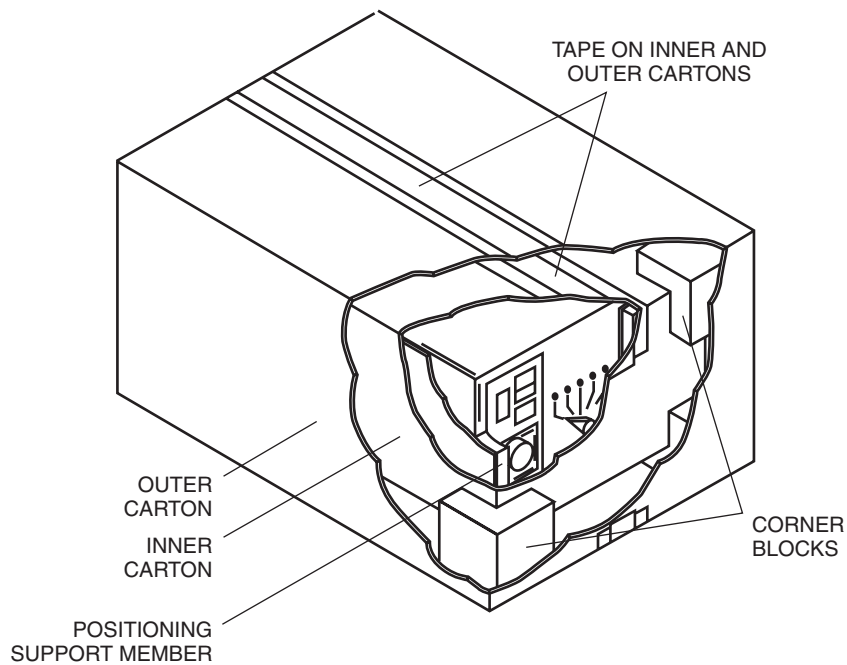

**Figure 2:** Dynacalibrator packaging

## Concealed Damage

Concealed damage is damage which is not apparent until after the equipment has been unpacked and examined or tested. In the event that concealed damage is discovered, a written request for inspection must be forwarded to the carrier's agent within 15 days of the delivery date. All cartons and packing materials must be kept intact for the inspection. Delay in submitting the inspection request or destroying the packing materials may give grounds for refusal of any claim.

After inspection, the carrier's agent will usually request the return of the equipment to VICI for inspection and repair. When this work is completed, the equipment will be returned to you with an invoice itemizing charges for all repairs. This invoice will become part of your claim to the carrier.

In the case of shipments made F.O.B. destination, VICI will, at your request, handle the filing of damage claims with the carrier provided an acceptable inspection report from the carrier is furnished to VICI. If, however, the claim is disallowed through no fault of VICI, repair charges will be billed directly to you.



**You must unpack and fully inspect the equipment and file a written request for inspection with the carrier within 15 days of delivery to ensure claim satisfaction in the event of concealed damage.**

## Unit Location

In general, the Dynacalibrator should be as close as possible to the analyzer to be calibrated, as long as:

- the ambient temperature is at least 2°C below the selected operating temperature of the permeation chamber.
- ambient temperature variations are minimal.
- exposure to precipitation and condensation is minimized.
- ambient particulate levels are minimal.  
(In the event that dust is prevalent, the unit should be equipped with a Metronics Particulate Filter Assembly.)
- air flow around the unit's cooling vents and rear panel fan intake is not blocked or restricted, particularly for the rack-mounted units.
- it is on a level surface, to prevent errors in flow determination caused by a non-vertical flowmeter



**When the Dynacalibrator is installed in an instrument rack, the user must make certain that the overall rack ventilation/cooling is adequate.**

---

A bench-mounted Dynacalibrator should be placed on a firm horizontal surface – preferably the same surface as the analyzer to be calibrated. A rack-mounted enclosure in a mobile installation (van, aircraft, etc.) requires additional mechanical support between the rack and the rear of the enclosure. This additional support is not needed for slide-mounted enclosures.

Once the Dynacalibrator has been unpacked and a location selected, check the packing slip included with the shipment to verify that all the ancillary parts (forceps, etc.) are available. In the event of a discrepancy, please notify VICI immediately.

## Permeation Device Conditioning

Dynacal permeation devices must be conditioned prior to their use in the Dynacalibrator. Proper conditioning ensures that the device performs at its specified mass permeation rate and accuracy.

Conditioning is accomplished primarily by heating the device for a specified time period in a temperature-controlled environment (at the intended operating temperature  $\pm 1^\circ\text{C}$ ) through which there is a steady purge of dry gas at a minimum of 80 cc/min.

Since conditioning for each specific device is a function of a variety of factors, inflexible rules or recommendations cannot be included here. Contact VICI Metronics for conditioning information for your permeation devices.

## Rear Panel Connections

Remove all shipping caps and shipping plugs from the rear panel bulkhead fittings. All these hardware items should be saved for reuse if the Dynacalibrator must be stored or returned to VICI.

Fitting locations are identical for all configurations. Fitting holes which are not used are equipped with blank caps. All connections are clearly marked and easily identified.

### Supply Inlet

All Model 345 Dynacalibrators are equipped with a supply inlet fitting. **(Figure 3)** Since there is no internal pump, the supply inlet must be connected to an external pressurized source of carrier and dilution gas such as an external pump, a cylinder of compressed gas, etc. The most commonly used gas is dry air; however, dry nitrogen may also be used.

#### Note about Model 345 for moisture:

The Model 345 for moisture must have an extremely clean, dry source of either Air or N<sub>2</sub>. Filters and traps for trace moisture should be used and maintained at all times to provide accurate low level moisture results. Along with filtration, use only metallic tubing and high-purity regulator and fittings for the supply of Carrier/ Diluent on all moisture systems.



**The pressure of the external gas source connected to the supply inlet must be at least 25 psig but no more than 50 psig. High pressure pumps and gas cylinders are potentially very dangerous. Use extreme care when making or breaking connections between the Dynacalibrator and external gas sources.**

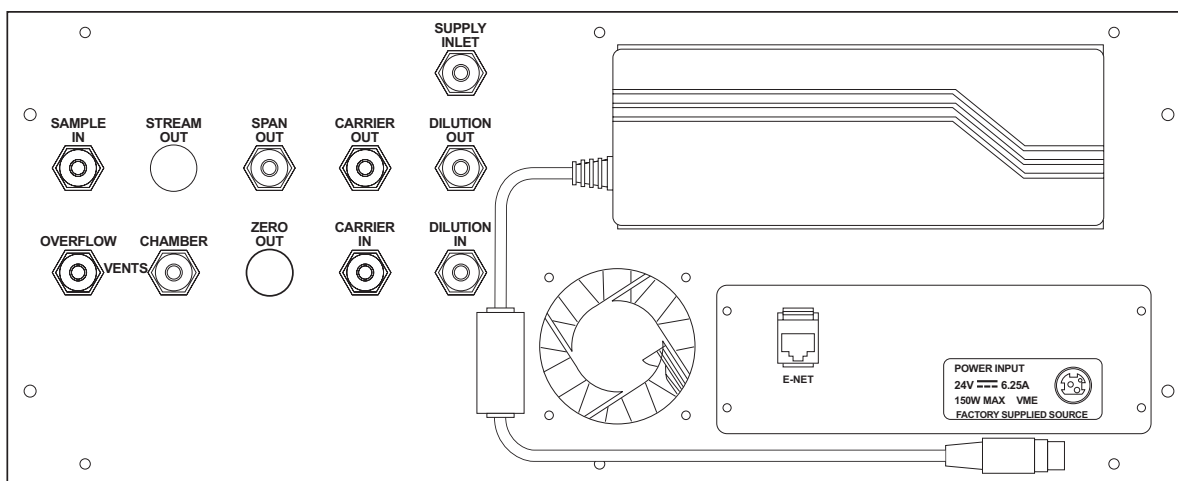

**Figure 3** Dynacalibrator 345 Rear Panel

## Span Outlet

The primary outlet on the Model 345 is labeled SPAN OUT. The SPAN OUT port may be either permanently plumbed to the calibrate input port of an analyzer or temporarily connected to its sample input for calibration, depending on the capabilities of the analyzer.



**NOTE: The Span Out port should be directly connected to the analyzer input with a minimum length of tubing. Altering the output stream in any manner may affect the concentration of calibration gas in the stream. Use tubing which will provide the low back pressure for the required delivery flow for the analyzer.**

## Overflow Vent

All Dynacalibrators include an overflow vent to dump excess calibration gas, ensuring that analyzers sensitive to sample feed pressure receive span gas at near atmospheric pressure. The overflow vent is therefore usually left open, or plumbed to an external exhaust point with large diameter tubing. External devices (filters, etc.) or tubing with too small a diameter on the overflow vent may cause an undesirable increase of pressure at the analyzer's input.

## Front Panel Features

### MAIN POWER switch

The rocker switch on the upper left corner of the front panel provides primary power to all circuits.

### PERMEATION CHAMBER

This is the high accuracy oven which holds the permeation devices. A tool is provided to rotate the panel lock screw 90° counterclockwise to unlock the cap. If the oven door is not in place and in the locked position, the oven will not be powered and will not heat. The actual chamber temperature is recorded into the database on one minute intervals, for a maximum period of one week.

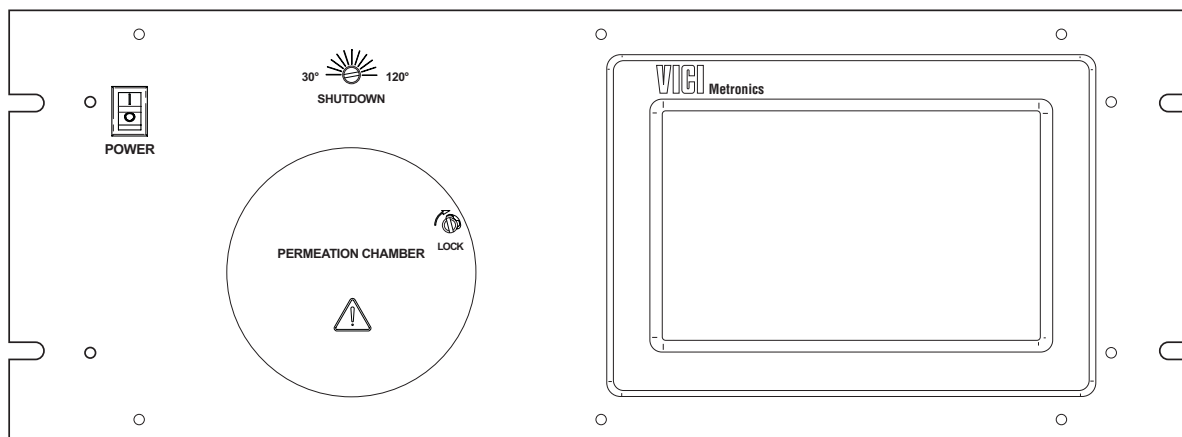

**Figure 4:** Model 345 front panel

**OVEN TEMPERATURE UPPER LIMIT**

A power-limiting thermostat provides a safety shutoff at this user-defined setpoint, usually 5-10 degrees above the normal run temperature of the permeation device in use. . If the oven runs out of control, or if a temperature setpoint is requested that is above the temperature limit, power to the oven heater is shut down and a "PFAIL" warning will indicate the need to check the temperature setpoint and cycle the power to reset the device.

The following functions, typically related to Dynacalibrator front panel analog components, are integrated into the touch screen display of the Model 235.

**CARRIER FLOW VALUES**

Carrier flow, which is the constant flow through the permeation chamber, is established at the factory and normally not editable. A fixed rate of 100 sccm is the normal flow rate for the carrier stream. The setting for this flow and the actual value of this flow can be seen in the MANUAL tab on the front panel display controller. Actual carrier flow is recorded into the database at one minute intervals, for a maximum period of one week.

**TEMPERATURE VALUES**

The chamber temperature setpoint and the actual values can be read and changed from the MANUAL tab of the front panel display controller. The chamber temperature can be set manually through the controls on the screen. After a temperature set point is entered by this method, it is written to memory so that in the event of a power failure the unit will return to the condition previously established. Actual oven temperatures are recorded into the database at one minute intervals, for a maximum period of one week.

**DILUTION FLOW VALUES**

The Dilution flow is set from the MANUAL tab on the front panel display controller. The response to a new setpoint should be established within approximately five seconds. Total flow (dilution + carrier) is recorded into the database at one minute intervals, for a maximum period of one week.

# Initial Set-Up

---

## Basic Connections

1. Plug the power cable from the main power connector on the rear panel of the calibrator to a 110 VAC power source (220 VAC with Model 340-C).
2. Remove caps from the SUPPLY INLET, SPAN OUT, and OVERFLOW VENT ports on the rear panel. (**Figure 3**)
3. Connect the clean, dry, regulated supply gas source (25 psig min, 50 psig max) to the carrier inlet on the rear panel. (**Figure 3**) The supply gas regulator must be able to source the maximum dilution flow, which may be as high as 20 SLPM.
4. Connect the span outlet to your instrument.



**Always leak check the entire instrument and all flow connections, particularly if toxic, corrosive, or flammable gas mixes will be generated.**

**Use clean/dry air or N<sub>2</sub> to perform a pressure/decay test to verify the leak integrity of the system before putting it into service.**

---

## Remote Control Connections

When the front panel mode selector is in the REMOTE position, the operating mode can be selected by providing contact closures between the two rear panel remote control terminals, labeled C (common) and V1. The contact closures must be capable of handling 24 VAC at 0.5 amps into an inductive load.

When C and V1 are open, the Model 345 is in the ZERO mode. When V1 is closed to C, the unit switches to the SPAN mode.

## Chamber Temperature

### Important Chamber Temperature Considerations

- If the chamber temperature exceeds the value set by the mechanical temperature limit switch, the heater will automatically shut down and a warning screen will appear on the touch screen controller.
- When the front panel door is removed, the heater automatically shuts down.
- Always refer to the separate instructions accompanying the permeation tube(s) to make sure that the selected temperature is compatible with the permeation tube(s) being used.

Once the gas connections are complete and the instrument has been leak tested, turn on the inlet supply gas. Plug in the power the power cord and switch the power on using the front panel switch. The touch screen panel provides the user interface for setting and checking the permeation chamber temperatures.

1. Open the Manual screen (**Figure 5**) by touching the "Manual" tab on the left hand side of the display.

2. Touch inside the white area of the "Temp: set point" field. When the UP/DOWN control appears (right), use it to reach the desired value.

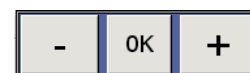

3. Select "OK" when finished.

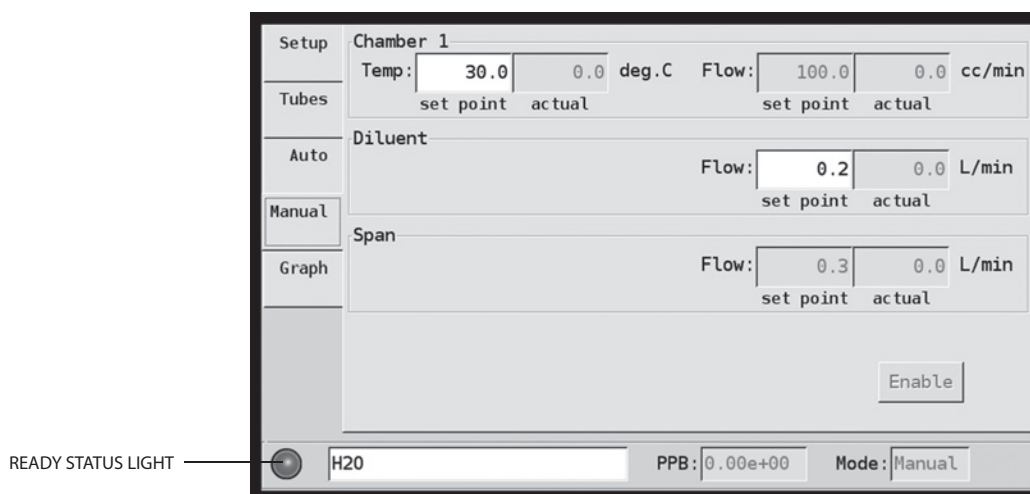

**Figure 5:** Model 345 Manual screen

NOTE: The Ready status light will be red while the oven is changing temperature. Once the oven temperature is within the control limits, the status indicator will change to green.

## Setting the Oven Temperature Limit

A mechanical thermostat is integrated with the temperature control circuit for fail-safe temperature control. This thermostat should be used to prevent accidental overheating of low temperature permeation devices or permeation devices containing toxic or hazardous chemicals. Overheating can rupture the device or cause an unintended release of chemicals.

The temperature markings on the front panel are approximate ( $\pm 10^{\circ}\text{C}$ ). For a more accurate setting:

1. Using a flat-tipped screw driver or the tool provided, adjust the setting all the way clockwise.
2. Turn on the Dynacalibrator main power. Do not install any permeation devices yet.
3. Set the chamber temperature  $5^{\circ}\text{C}$  higher than the desired operating temperature, and wait for the status indicator to change from red to green, indicating that the chamber has equilibrated.
4. Once thermal equilibrium is achieved, slowly adjust the setting clockwise until the touch screen displays a box indicating "PFAIL." (You may hear a faint click.)

Oven Temperature Limit has been triggered.  
Please check the setting of the Temperature Shutdown limit. Reset of this limiter requires switching power OFF and ON again. Please do so after verifying the limit switch settings.

**Figure 6:** Model 345 PFAIL indication

5. Turn off the power switch and wait 15-20 minutes for the chamber to cool.
6. Turn on the heater power switch and set the chamber operating temperature.



**When PFAIL occurs, the Dynacalibrator must be turned off long enough for the chamber to cool before the power is turned back on.**

## Installing the Permeation Device(s)

1. Reduce the temperature setpoint for the permeation chamber to 30°C. Allow time for the chamber to cool to this temperature, which will be indicated by the status indicator changing from red (*not ready*) to green (*ready*).
2. Turn off the main power switch on the front panel.
3. With the tool provided, rotate the panel lock screw 90° counterclockwise.
4. Remove the front panel oven cover to access the permeation chamber cap.



**CAUTION:**

**The permeation chamber cap may be warm to touch. If the calibrator has been in use, avoid exposure to gas vapors while opening the chamber cap by using appropriate mitigation and personal protection equipment.**

5. Unscrew the chamber cap with the tool provided.
6. Add or remove the permeation device(s) with the supplied forceps or other tool appropriate to the job..
7. Secure the chamber cap with the tool provided.
8. Run a pressure/decay test to make sure that the chamber cap is leak tight.
9. Reinstall the front panel assembly and rotate the panel lock screw 90° clockwise.
10. Turn on the power switch.
11. Enter the new permeation device parameters (*refer to "Tubes Screen" on page 14*). and the new temperature set point for the chamber (*refer to "Setting the Chamber Temperature" on page 10*).

Refer to the device-specific instructions accompanying the permeation tube to ensure that the temperature entered is a safe operating temperature.

12. To establish the desired concentration, set flows from the Manual screen or set concentration from the Auto screen (*page 16*).

Allow time for equilibration. When the status indicator changes from red (*not ready*) to green (*ready*), equilibration has been achieved and the Dynacalibrator is ready to be put into service.



## Configuration

The Model 345 has been designed to provide high accuracy dilution of permeated gases in both automatic and manual operation modes with minimal configuration. The input necessary to configure the instrument is accomplished on two screens, the Setup and Tubes screens. The specifics for each permeation device and the time, date and units of measure are all that is required for configuration.

### Setup Screen

Select the Setup screen by touching the "Setup" tab on the left hand side of the display. On this screen, the following parameters are established:

#### Concentration units

Concentration units are chosen by selecting PPM or PPB.

#### Minimum flow

This is factory set to 300 cc/min, the minimum total flow on the Model 345.

#### *To input a new (higher) value*

Touch inside the white text field, then use the numeric keypad to input the new value. Select "Enter" to apply the change and hide the input pad.

#### *To revert to the previous data*

Select "Cancel" to revert to the previous data and hide the input pad.

#### *To remove incorrect input*

Select "Clear" to remove incorrect data and input new data.

#### Date/Time

To change the date/time:

1. Select the "Change" button to the right of the Year/Month/Day display.
2. Touch the white field for the year, month, or day to open an input control.
3. Use the +/- buttons to adjust the value, then select "OK" to enter the selection for that box.
4. When all boxes are properly configured touch the "Apply" button.
5. Select "Yes" to accept the new values, or "No" to cancel the operation.



**Changes to the date and/or time will completely delete all prior flows/temps/concentrations previously stored in memory.**

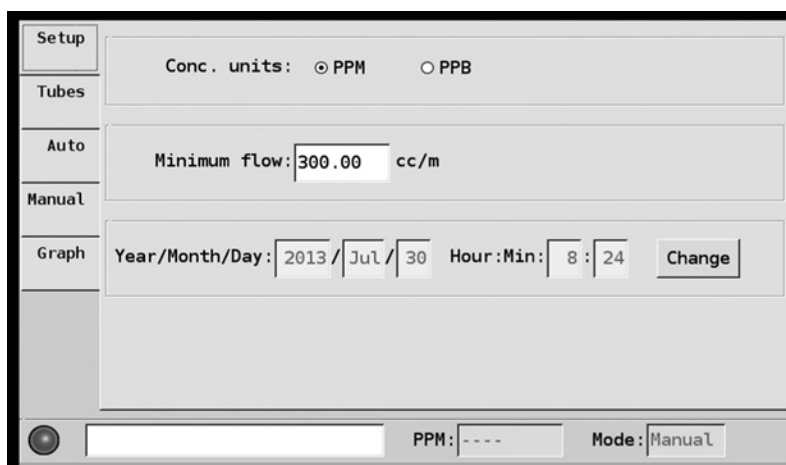

**Figure 7:** Model 345 Setup screen

## Tubes Screen

Select the Tubes screen by touching the “Tubes” tab on the left hand side of the display. On this screen, the following parameters are established:

### Compound

To select the correct compound:

1. Touch the white area of the Compound text field to open the pull-down menu.
2. Scroll down to select the desired compound. The pull down menu will disappear and the compound name will update in the Compound textbox.

Note: If the compound is not in the table of compounds, then Manual mode settings will be used for the calculation and input of flows/temperatures for delivering the desired concentrations.

### Permeation rate

Permeation Rate is the value supplied on the permeation certificate in ng/min. To enter the correct permeation rate:

1. Touch inside the white area of the Permeation rate text field to open the numeric input pad.
2. Use the numeric keypad to input the desired value.
3. Select “Enter” to apply any change and hide the input pad.  
Select “Cancel” to revert to the original data and hide the input pad.  
Select “Clear” to remove incorrect data and input new data

### Temperature

Temperature is the value supplied on the permeation certificate in °C. If the device is not certified, use the temperature on the device label.

To enter the correct temperature:

1. Touch inside the white area of the Temperature text field to open the numeric input pad.
2. Use the numeric keypad to input the desired value.
3. Select “Enter” to apply any change and hide the input pad.  
Select “Cancel” to revert to the original data and hide the input pad.  
Select “Clear” to remove incorrect data and input new data

NOTE: If more than one tube will be in the permeation chamber, add the additional tubes by touching the “+” sign on the overhead tab of the Tubes input screen and repeating these operations.

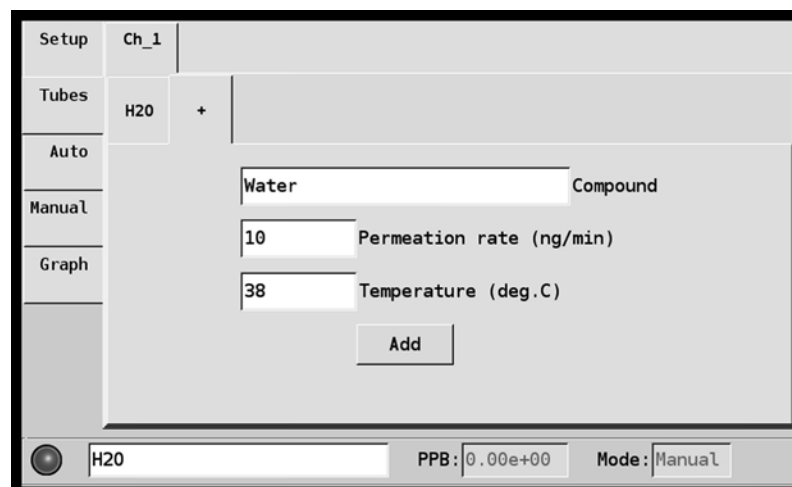

Figure 8: Model 345 Tubes screen

## Basic Operation

### Important Permeation Device Considerations

- If more than one tube is to be used in the oven at the same time, order all the tubes with permeation rates given at the same temperature.
- Certified permeation devices should be used only at the temperature specified on the certificate.
- Using any permeation device beyond its recommended temperature range could result in the destruction of the device by explosion and/or changes in the membrane characteristics. If in doubt, contact VICI Metronics or their authorized representative with the part number of the device to determine its maximum temperature limit.

### Manual Mode

Concentration of the permeant compound in the span outlet stream is inversely proportional to the carrier flow rate through the chamber. In the Manual mode of operation, use the following formula to establish the dilution flow rates to achieve the desired concentration.

$$\text{Concentration (ppm)} = \frac{K * P}{F}$$

Where: K = 24.45 / molecular weight of gas  
 P = permeation rate in ng/min (information included with the permeation device documentation)  
 F = Total flow: sum of carrier flow (100 sccm on standard instrument) and diluent flow

If the permeation rate is known for some reference temperature, the rate at a second temperature can be estimated as follows:

$$\log P = \log P_o + 0.034 (T - T_o)$$

Where: P<sub>o</sub> = Permeation rate at reference temperature T<sub>o</sub>  
 P = New permeation rate at temperature T

### Sample Calculation

Given:  
 Permeation rate: 21,000 ng/min Cl<sub>2</sub> @ 30°C  
 Carrier flow: 500 ml/min

Then: Concentration (ppm) = (K\*P)/500= 14.5 ppm

For zero reference measurement, remove the permeation device from the chamber.

Once the calculations have been rendered, enter the Manual mode of operation by select ng the "Manual" tab on the display controller. Enter the value for Temp Set point and Diluent Flow Set point (**Figure 9**) To enter a new value, touch inside the white area of the field and use the up/down controller to alter the value. Select "OK" when finished.

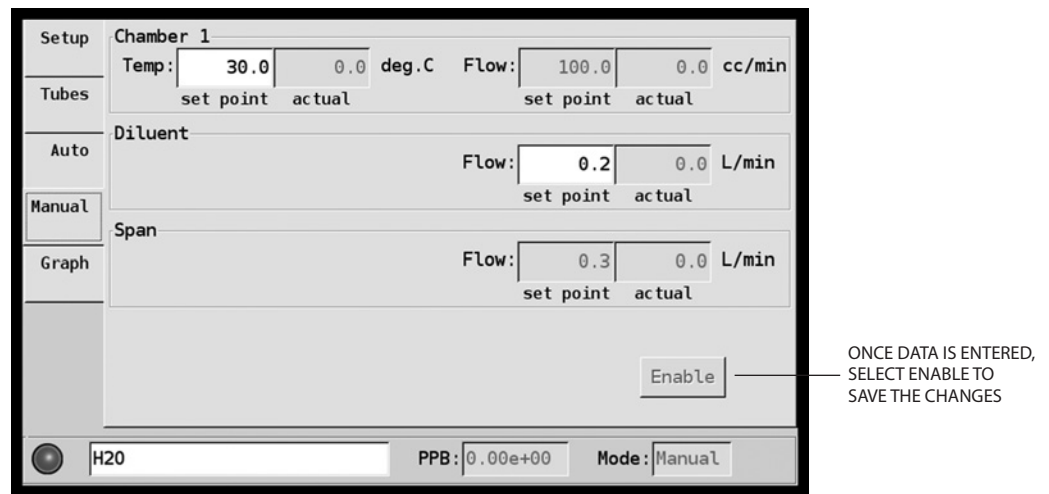

**Figure 9:** Model 345 Manual screen

Once the correct values are input in the correct fields, select the "Enable" button on the lower right hand portion of the Manual screen. If this Enable step is omitted, the changes will be lost when you navigate to another screen.

NOTE: When changes to this screen are made and enabled, the Status indicator will be red for a preset period of time. This time is dependent upon the kind of change made and the length of time required for the change to become equilibrated. For example, resetting the permeation chamber temperature from 30°C to 75°C could require up to two hours to reach equilibration, at which point the Status indicator will change to green.

## Auto Mode

After configuring the Dynacal 345 with at least one permeation tube (*refer to page 14 as required*), the user may elect to run an automatic mode of operation. The auto mode uses the power of the Touch Panel Controller to calculate the set points required to achieve the available range of concentrations for a given permeation tube or tubes. Once the user input is complete, the flows are automatically set to achieve the requested concentration of the permeate compound to the span outlet stream.

In Auto mode, all controlled variables are logged once per minute, with flows, temperatures, and concentration calculations stored in a database. See the fuller description in the section entitled "Historical Display Graph" beginning on page 18.

### To use auto mode:

1. Make sure that all configuration data has been input. Check that the data for the permeation tube has been entered properly in the Tubes tab. If there is more than one tube, ensure that all tubes are entered correctly.
2. Select the "Auto" tab on the left hand side of the display controller.
3. Touch inside the white text box labeled "Compound". A pull-down menu will appear, allowing you to select from the tubes that have been installed at the Tubes tab.

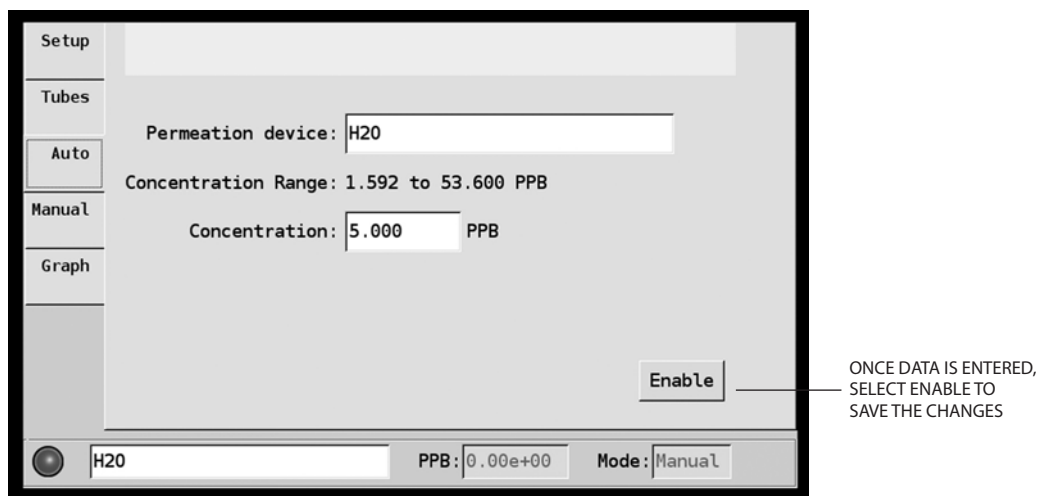

**Figure 10:** Model 345 Auto screen

4. Select the particular tube to be used as the basis for calculations by touching on the tube name. The pull down will roll up and the selected entry will occupy the text box labeled “Compound”.

As soon as the tube is selected, the Concentration Range line will be populated with the minimum and maximum concentration available with this tube.

5. Input the desired concentration by pressing inside the white text box labeled “Concentration” and using the pop-up numeric keypad to enter the value desired. (If a value outside the available range is requested, the value will be forced to the closest value achievable.)
6. Touch the “Enable” button to initialize the instrument in Auto mode with the requested settings. Failing to select “Enable” and leaving this screen will render the input invalid.

NOTE: When changes to this screen are made, the Status indicator will be red for a preset period of time. This time is dependent upon the kind of change made and the length of time required for the change to become equilibrated. For example, resetting the permeation chamber temperature from 30°C to 75°C could require up to two hours to reach equilibration, at which point the Status indicator will change to green.

## Quick Glance Status Bar

The Dynacal 345 touch panel provides a continuously visible display at the bottom of the screen for an easy view of the current status of the instrument. (**Figure 11**) The user can verify at a glance the overall status (Ready/Not Ready), the concentration of the selected calibrant, and the current Mode of operation (Auto/Manual). The user may also select and verify all other active permeation tube concentrations by touching inside the Device box and selecting from the pull down of installed devices. Concentration will update upon selection.



**Figure 11:** Quick Glance Status Bar

**Status indicator**

A red indicator means Not Ready, which can reflect one or more of the following:

- Flow outside of tolerances
- Temperature outside of tolerances
- Equilibration period not satisfied

NOTE: The equilibration period does not begin until the instrument meets all criteria for a Ready status. Therefore the Ready status (green) will not appear until a preset time after the initial achievement of the Ready requirements. The equilibration period for Flow is five minutes. This means that when a flow setting is changed, once it stabilizes at the new setpoint (that is, once it stays within the Flow tolerance limit), the flow equilibration period timer will start the five minute countdown sequence leading to a green Ready status. The equilibrium period for temperature is one hour. When an oven temperature set point is changed, the one hour timer does not initiate the countdown until the chamber is within the temperature tolerance limits. This time allows for down stream stabilization and equilibrium to occur at the new concentration.

**Permeation device display and selector**

This is an interactive status box that displays the name of one of the loaded calibrant tubes. To select another active tube, touch inside the white text field to open a pull-down menu of the available tubes, and touch one to select it. The text field will update with the new permeation tube name or chemical symbols, and the concentration will update to show that tube's current output level.

**Concentration**

This field displays the real-time calculation of the concentration of the permeant displayed in the permeation device display. This value will update several times per minute.

**Mode**

This shows the current operation mode—Manual or Auto.

## Historical Display Graph

The Dynacal 345 logs up to seven days of historical data, with flow, concentration, and temperature continuously logged at one minute intervals. All critical setpoints and calculations for all installed permeation devices are captured.

Selecting the "Graph" tab presents the user interface for looking at all logged data for the past week. (**Figure 12**) Resolution down to individual point values can be reviewed and presented in the following categories.

**Conc**

Selecting the Conc button will display the concentration record for the active permeation device. The initial view is 10 Hours, but by selecting the 24 Hour button on the lower left hand corner of the graph, you can see 24 hours of data. Touching it again will display 7 days of historical data for concentration. To review the concentration values for other installed permeation devices, touch inside the Permeation device field in the Quick Glance Status Bar and

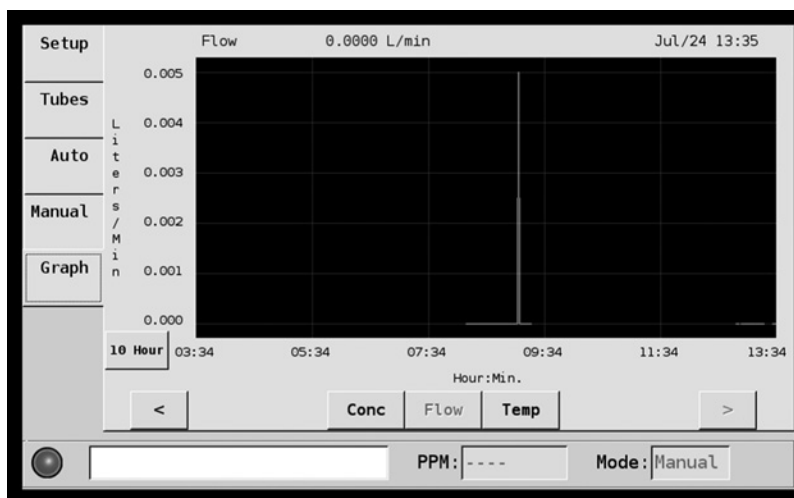

**Figure 12:** Model 345 Graph screen (Flow)

select from the installed devices, and the graph will update with the historical data of the selected device. Use your finger to scroll from right to left along the line. As the cursor moves, the exact measurements of each point will be displayed, along with the date and time of the recording of that data point.

#### **Flow**

Select the Flow button to display the total flow logged for the instrument on a 10 hour, 24 hour, or 7 day graph. You may scroll to a particular point of interest by touching anywhere inside the graph screen to resolve down to a single point, whose value is then presented at the top of the graph

#### **Temp**

Select the Temp button to display the oven temperature values in °C. Choose the 10 hour, 24 hour, or 7 day graph, then scroll to an individual point on the line. Time and value of the point will be shown in the border above the graph.

## Analyzer Calibration

---

When the power-up procedure is completed and the chamber temperature, flow, and permeation device have reached equilibrium, the system status indicator in the lower left hand corner of the display will give a "Ready" (green) status. This indicates that the Dynacalibrator is ready to be connected to the analyzer to be calibrated.

Use a minimum length of tubing for the connection, and ensure that all of the Dynacalibrator's vents are open.

If the Model 345 is to be used for a multipoint calibration:

### Manual Mode

1. Adjust the dilution flow on the Manual screen for each of the pre-calculated span points. After each flow change, the status indicator will be red (*not ready*) for an equilibration period before returning to green (*ready*).
2. Upon completion of the range of dilutions for the calibration, remove the permeation device from the oven, reseal the oven, and allow it to equilibrate until the status indicator turns green (*ready*).
3. Run this final point in your instrument calibration as the ZERO point for your calibration curve.

HINT: Running your concentration curve from highest to lowest concentration is the preferred method to approach Step 3 in this procedure.

### Auto Mode

1. From the Auto screen, input the concentration required for the calibration point.
2. Enable the change, and wait for the Ready status.
3. Run the analyzer at the calibration point. After the last calibration level, skip to step 5 to run the Zero level.
4. Repeat steps 1 - 3, moving from the highest concentration to the lowest concentration.
5. Let the permeation oven and cool, and remove permeation device. Reseal the oven.
6. Go to the Tubes screen and select ZERO as a compound, and enter "0" ng/min. Do not change the temperature. Select the "Add" button.
7. Go to the Auto screen and select compound ZERO. Enter "0" in the concentration field. Allow time for equilibration and the Ready status indication.
8. Run the analyzer at the Zero point.



---

## Shutdown Procedure

---

Dynacalibrators are designed to operate continuously; however, if it is necessary to turn the unit off, use the following procedures:

1. On the Manual screen, set the Temp to 30, and select the "Enable" button.
2. Allow the oven to equilibrate at this temperature
3. With the tool provided, rotate the oven door lock screw 90° counterclockwise.
4. Gently pull the front panel assembly out.



**CAUTION:**

**Use specific and appropriate precaution when opening the calibrator oven. Use procedures and protective equipment to avoid contact or exposure to the permeation device and/or gas vapors while opening the chamber cap and adding/removing/changing oven content.**

---

5. Unscrew the chamber cap with the tool provided.
6. Remove the permeation device(s) with the supplied forceps or other tool appropriate for the job.
7. Secure the chamber cap with the tool provided,
8. Reinstall the front panel assembly and rotate the panel lock screw 90° clockwise.
9. Place devices in the containers provided and store them in an appropriate place until further use is required. (A refrigerator or freezer is recommended.)
10. Allow the carrier flow to purge the chamber for at least five minutes.
11. Switch off the main power.
12. If the unit will be left unpowered for an extended length of time, disconnect all the plumbing from the rear panel inlets and outlets and cap all open ports.

When repowering the unit, always perform the start-up procedures starting on page 10.

## Advanced Theory of Operation

Dynacalibrator operation is based on the principle of mixing a known mass flow of gas derived from a permeation device with a metered stream of clean carrier/dilution gas to generate a precise concentration of span gas.

User-selectable calibration gases originate from Dynacal permeation devices which are maintained at a user-selectable constant temperature within the Dynacalibrator's permeation chamber. Permeation rates can be precisely determined gravimetrically as a function of temperature.

An internal flow regulating system ensures a stable gas flow over extended periods of time for both the carrier air and dilution air streams. The carrier stream continuously sweeps the permeation gas from the permeation chamber. This stream then mixes with the dilution stream to provide the final calibration as supply.

Different span gas concentrations can be generated by changing one or a combination of the following parameters: (1) the dilution stream flow rate, (2) the permeation chamber temperature, or (3) the number and/or type of permeation devices. The fastest, simplest, and most common method is to change only the dilution flow rate.

The carrier flows at a fixed rate, maintained at a constant value by a sapphire orifice plate and a differential pressure regulator. Orifice sizes are available for rates of 80-1300 cc/min.

The dilution flow is user-adjustable from approximately 100 cc/min to over 20 liters/min, depending on the capacity option selected. Model 340 Dynacalibrators contain a single dilution flow control valve and rotameter. Since the Model 340 can provide a wide dynamic range of span gas calibrations simply by changing the flow rate of the dilution gas, it is considered to be a multi-point calibrator of exceptional range, accuracy, and precision.

Each Dynacalibrator model contains basic pneumatic plumbing, with several configuration options. The plumbing configuration selected (see the simple diagram below) processes the input gas supply into a carrier stream and a dilution stream. The carrier stream picks up the calibrated trace gas and is subsequently mixed with the dilution stream for the desired output concentration.

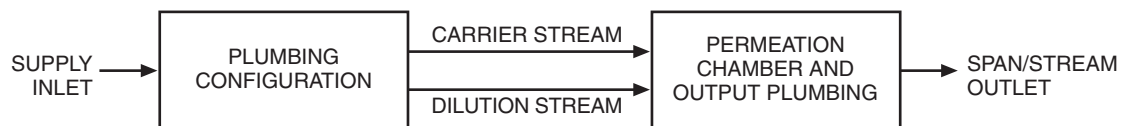

**Figure 13:** Basic block diagram

## Electrical Description

---

Dynacalibrators are powered from a benchtop style transformer on the rear panel. This is a switcher-style supply that allows a range of input voltage and frequency from 100 to 240 VAC at 50-60 Hz. The power supply steps the voltage down and regulates the output to 24 VDC. If the cord end type is inappropriate for your locale, please contact VICI for a replacement cord.

The main power switch is on the front panel. When the main power switch is on, 24 VDC energizes the main power indicator on the front panel, as well as the fan, mass flow controllers, and permeation oven.

There are no user serviceable parts within the Dynacal 345. If a suspected problem arises with the instrument, please contact the factory.

## Maintenance

Since the Dynacalibrators are designed for and generally used in applications that require continuous service, a planned routine maintenance program is highly recommended. Routine maintenance consists of inspection, cleaning, calibration, and leak checks. The table below lists the recommended checks and maintenance frequencies for continuous and non-continuous use. The recommendations are provided to help you keep your unit in peak operating condition and avoid catastrophic failures at inopportune times.

Use the shut-down procedures on page 26 to remove the unit from service and the initial startup procedures on page 15 to return it to service.

Maintenance action	Recommended schedule	
	Continuous use	Periodic use
Instrument inspection and cleaning	Quarterly	1000 hours
Leak check	Quarterly	1000 hours
Carrier flow rate verification	Quarterly	1000 hours
Filter inspection and cleaning	Quarterly	1000 hours
Dilution flowmeter calibration	Annually	4000 hours
Chamber temperature calibration	Annually	4000 hours

### Instrument Inspection and Cleaning

The following procedure should be performed quarterly for units in continuous service or at least after every 1000 hours of service. For the steps which call for disassembly, see the appropriate paragraph in this section.

1. Remove the unit from service according to the shut down procedures on page 36. Disconnect all power and plumbing.
2. Remove the top cover of the unit by unscrewing the six allen screws on each side of the instrument, above the side bars.
3. Snap the black fan screen off the rear and soak it in warm water with a mild detergent. Do not use a solvent.
4. Remove the four screws, hex nuts, and lockwashers that attach the fan to the rear panel. Remove the fan filter and soak it with the fan screen in warm water and a detergent.
5. Blow out the interior of the unit thoroughly with dry, low-velocity air. Remove any dirt that remains with a soft paint brush.
6. Clean the fan blades with a soft paint brush or a soft cloth dampened in the water and detergent solution.
7. Clean the exterior surfaces of the unit with a soft cloth dampened in the water and detergent solution. Do not use an abrasive.
8. Inspect all assembly mountings for loose hardware, and tighten as necessary.

9. Rinse the fan screen and fan filter in clean water and blow dry with low-velocity air.
10. Reinstall the fan, fan filter, fan screen brackets, and fan screen using the four screws, lockwashers, and hex nuts.
11. Replace the top cover of the unit and return it to service according to the procedures on page 15.

## Dilution Flowmeter Calibration

VICI recommends that Dynacalibrators be returned to the factory for NIST-traceable flow certifications, unless you have access to sophisticated flow measuring equipment.

## Chamber Temperature Calibration

Prior to shipment, the permeation chamber digital temperature control is calibrated against the temperature of the gas in the permeation chamber using an NIST-traceable PRT, (platinum resistance thermometer). The results of this calibration have been supplied with your instrument.

At this point, it is helpful to give an overview of the total calibration process. A multiple point measurement is made with excursions to the extremes of range. The values logged during this process allow a calculation of correction that gives very tight agreement between the measured and the setpoint values. This calibration equation is downloaded into the control board, correcting the temperature output values to be within the tolerances of the controller.

In point of definition, measured temperatures are the equilibrium temperatures that result at specific temperature setpoints. Calibration is done by running multiple setpoints to characterize the response of the controller and oven. This characterization is then modeled and corrections are calculated based on the model response. The corrections are input and then the multiple setpoints are again run with the PRT, and must fall within the specification in order to move to final assembly. To define this process further is outside of the scope of this document and the range of work that is done by field services.

Calibration temperatures are integral Celsius temperatures ( $\pm 0.1^\circ\text{C}$ ) that will exist in the permeation chamber at specific digital settings. These temperatures are always expressed in integers, since all permeation device calibrations are performed at integral Celsius temperatures. Dynacalibrator calibration temperatures are NIST-traceable to match permeation device calibrations which are also NIST-traceable.

Recalibration of all points is normally not required nor indicated. Recertification on an annual basis is recommended at the temperature setpoints where permeation devices will be used. Example: If an  $\text{H}_2\text{S}$  permeation device is going to be used at  $55^\circ\text{C}$ , and a COS tube is being used at  $40^\circ\text{C}$ , then the recertification should be done at 2 points,  $55^\circ\text{C}$  and  $40^\circ\text{C}$ . This reduces the cost of recertification and cuts down considerably on the time in test.

# Model Number Breakdown

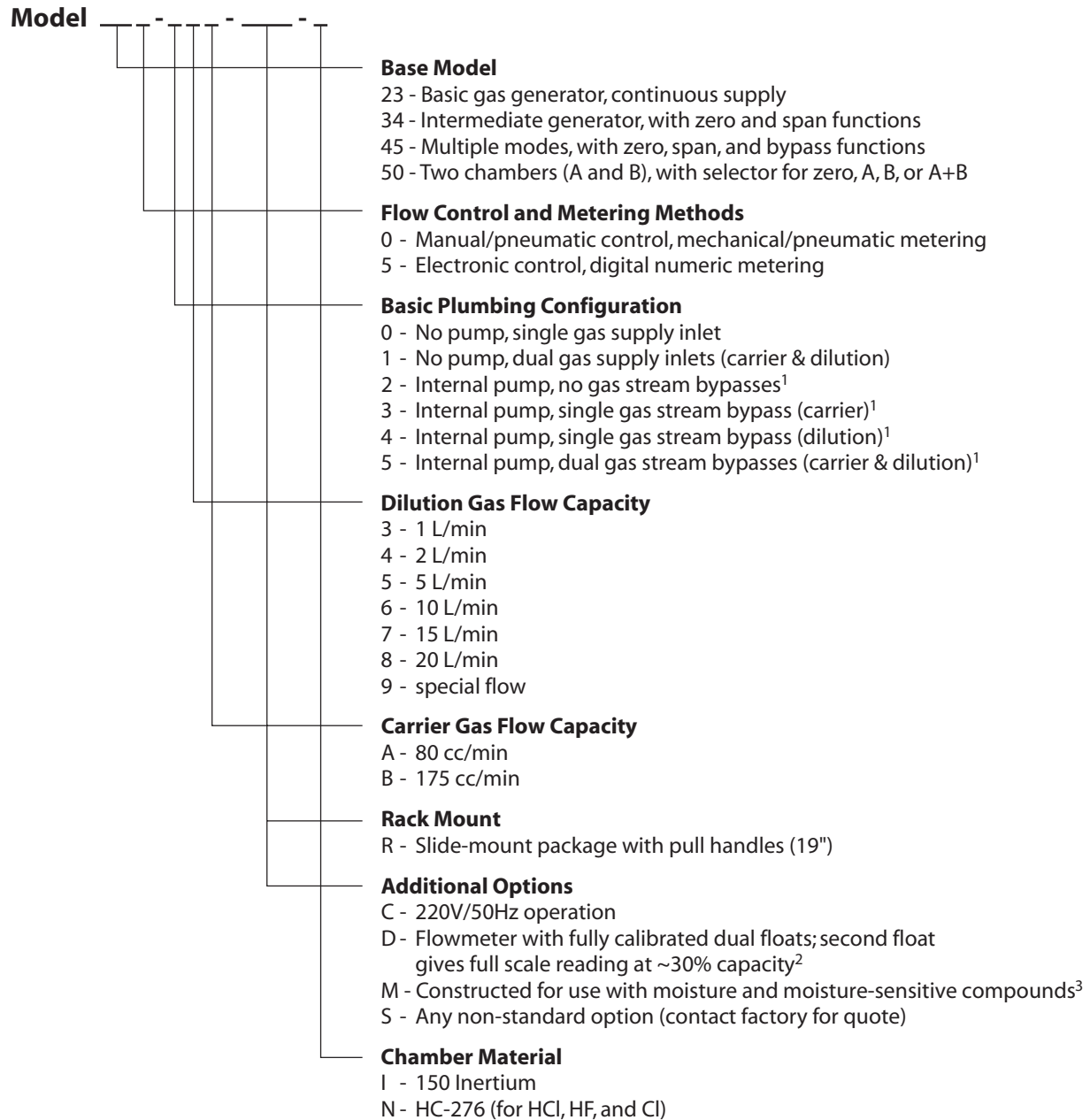

<sup>1</sup> Internal pump not available on Model 500/505, or on any model constructed for use with moisture (Option M)

<sup>2</sup> Available only on models with manual/pneumatic flow control

<sup>3</sup> Available only on models with electronic flow control

## Accessories

Name	Description	Product No.
<b>PFA</b>	Low-pressure-drop particulate filter assembly for Dynacalibrators with an internal pump which will be operated in dusty environments	50-02-102
<b>FC</b>	Replacement filter cartridge for PFA	07-10-016
<b>CSU</b>	Replacement charcoal scrubber unit	50-02-041
<b>PD</b>	Replacement pump diaphragm	07-05-001
<b>LF</b>	Replacement 5 micron line filter element, with gaskets	07-13-005

## Warranty

---

This Limited Warranty gives the Buyer specific legal rights, and a Buyer may also have other rights that vary from state to state. For a period of 90 calendar days from the date of shipment, VICI Metronics Inc. (hereinafter Seller) warrants the goods to be free from defect in material and workmanship to the original purchaser. During the warranty period, Seller agrees to repair or replace at Seller's option defective and/or nonconforming goods or parts (exclusions noted below) without charge for material or labor, subject to inspection FOB VICI Metronics Inc. factory. Buyer's exclusive remedy is repair or replacement of defective and nonconforming goods.

***Seller excludes and disclaims any liability for lost profits, personal injury, interruption of service, or for consequential incidental or special damages arising out of, resulting from, or relating in any manner to these goods***

This Limited Warranty does not cover:

- lamps or fuses
- damage due to improper shipping
- damage due to improper use
- damage due to modifications or alterations
- damage due to improper maintenance.

This Limited Warranty does not cover defects, damage, or nonconformity resulting from abuse, misuse, neglect, lack of reasonable care, modification, or the attachment of improper devices to the goods. This Limited Warranty does not cover expendable items. This warranty is VOID when repairs are performed by a nonauthorized service center or representative.

***The warranties contained in this agreement are in lieu of all other warranties expressed or implied, including the warranties of merchantability and fitness for a particular purpose.***

This Limited Warranty supercedes all prior proposals or representations oral or written and constitutes the entire understanding regarding the warranties made by Seller to Buyer. This Limited Warranty may not be expanded or modified except in writing signed by the parties hereto.